

---

GOVERNMENT OF NEWFOUNDLAND AND LABRADOR  
DEPARTMENT OF ENVIRONMENT AND LABOUR

---

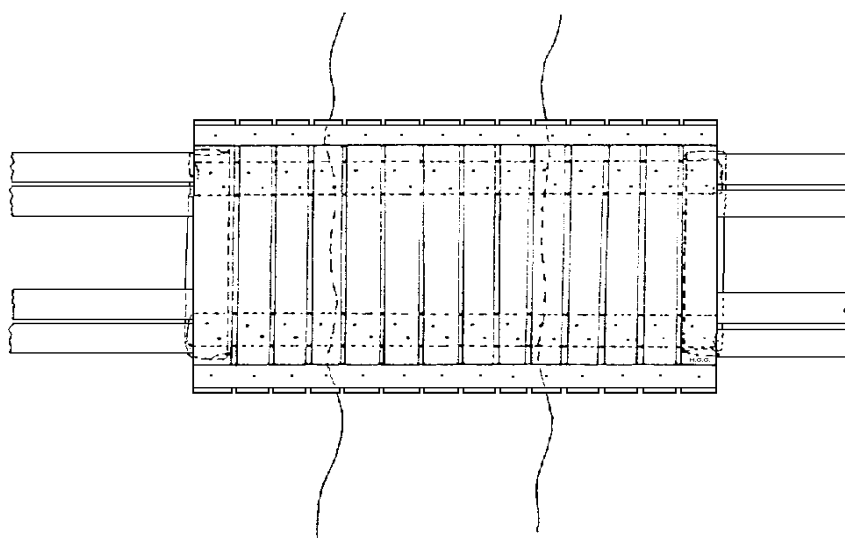

---

**CHAPTER 3A**  
Environmental Guidelines for  
**STREAM CROSSING BY  
ALL-TERRAIN VEHICLES**

---

---

WATER RESOURCES MANAGEMENT DIVISION  
Water Investigations Section

---

Chapter 3A

Environmental Guidelines For

**STREAM CROSSING BY ALL-TERRAIN VEHICLES**

Water Resources Management Division  
Water Investigations Section

March 31, 1994

**Table of Contents**

	Page
1. Introduction .....	1
2. Selection of Route and Crossing Sites .....	2
3. Fording .....	3
4. Bridges .....	4
a. Bridge Location .....	4
b. Bridge Capacity .....	4
c. Bridge Type .....	5
5. Construction Practices .....	7
6. Inspection, Maintenance, and Other Concerns .....	8
7. Site Restoration .....	8
8. Applying for Environmental Approval for Stream Crossings .....	8

**List of Figures**

1. Profile and Plan of a Simple ATV Bridge .....	6
--	---

**1. Introduction**

The purpose of these guidelines are to outline a simple yet consistent methodology for crossing small streams or any other body of water with all-terrain vehicles (ATVs) on licensed trails or any other "approved area" as defined in the *All-Terrain Vehicle Use Regulations, 1994*. Those regulations specify in Schedule B, Terms and Conditions of Licensed Trails, that all stream crossings must be authorized by a Certificate of Environmental Approval issued by the Minister pursuant to Section 11 of the *Environment Act* prior to trail construction. These guidelines will assist any prospective licence holder with making a proper application for the stream crossings that might be required for the licensed trail

The main objective in requiring approval for stream crossings is to ensure that the least possible disturbance occurs when crossing streams. In fact, the best approach is to avoid crossing streams whenever possible by selecting routes that do not cross streams at all. Only when avoidance is not possible or practical, should we consider making a stream crossing. There are several alternatives such as fording or building bridges and these are discussed in the following pages. Generally for frequent crossing of the same watercourse, a bridge structure is recommended. These guidelines provide a design for a very simple wooden bridge that can be built with just a few logs, boards and nails. Nothing elaborate is required as long as the structure spans the stream and thereby avoids instream travel and prevents disturbance of the stream banks. These guidelines also discuss some good construction practices and restoration measures.

### **3A ATV STREAM CROSSINGS**

#### **2. Selection of Route and Crossing Sites**

In planning ATV trails careful consideration is required in selecting a route to mitigate the impact on all water resources.

Routes should be selected to:

- minimize the number of watercourse crossings,
- avoid steep slopes and other sensitive areas,
- avoid wetlands and floodplain areas,
- reduce travel and access through Protected Water Supply Areas, and
- maintain substantial buffer strips of 15 metres on all bodies of water.

Where there is a choice between alternative crossing sites on the same watercourse the crossing should be located:

- where the stream is straight, unobstructed, and well defined,
- on an exiting right of way if one exists,
- where stable geological and soil conditions are present,
- where a minimum of scour, deposition, or displacement of sediments are expected to occur at or near a crossing,
- where possible effects on existing bridges and hydraulic structures can be avoided,
- where it is possible to minimize the risk of damage from environmental hazards such as floods, mudslides, or fires,
- where aesthetic conditions are favourable, and,
- away and preferably downstream from such areas as fish spawning sites or water intakes.

Much of the information required for selecting a site and for deciding the best method of crossing is obtained from a site inspection. Physical measurements of the stream should include its width at top and bottom, the depth of channel from top of embankment to bottom of stream as well as the depth of water and its flow velocity. Other necessary information includes:

- type and grading of bed material,
- existence of shoals and their composition,

- the type of material forming the stream banks,
- type and density of vegetation on the banks,
- steepness of banks and evidence of erosion,
- debris marks on shrubs, trees, or banks which may indicate the level of recent floods, and,
- elevation of ice scars which may indicate ice jam elevations.

**3. Fording**

There are a number of environmental factors to consider in deciding whether to ford a watercourse or to provide a structure such as a bridge or culvert.

If a location with stable channel bed and banks has been identified, the flow is not too deep, and very infrequent use is anticipated, fording may be an acceptable alternative to the installation of a bridge or culvert. In some cases the installation of a bridge or culvert and its subsequent removal would result in greater channel disruption than preparing a fording site.

The fording site must be located at a shallow section of the channel where there are low approach grades, and where the channel consists of stable non-erodible rock or cobbles or better yet, exposed bedrock. Any areas with vegetated, silty, or sandy bottoms are not considered acceptable fording sites.

Timbers or rocks may be placed in the stream to facilitate crossing or to minimize damage to the channel section provided the stream is not unnecessarily constricted or backed up.

Stream banks at fording sites that contain loose or erodible material must be adequately stabilized before crossing to minimize any siltation of the stream. This can be done by placing brush mats, rocks or timbers on the stream bank. This material must be removed after use of the fording site is completed.

Fording may only be carried out during periods of low flow.

All vehicles and equipment must be clean and in good repair, free of mud and oil, or other harmful substances that could impair water quality.

### **3A ATV STREAM CROSSINGS**

#### **4. Bridges**

Bridges are the preferred type of stream crossing because only bridges can avoid the alteration of flow regimes and protect the integrity of the stream channel. Bridges are recommended on all watercourses supporting fish because there is no need to disturb the streambed. Bridges must have sufficient flow capacity to ensure that flow velocities are kept slow enough or at their natural speed so that fish can swim upstream past the bridge. Culverts can be a fish barrier in this regard.

The proponent should avail himself of sufficient expertise to design and construct a crossing structure that will be sufficiently strong to safely carry a fully loaded ATV.

Creosote treated wood must not be used within 15 metres of a body of fresh water. For this reason, bridges over fresh water should not use any lumber that originates from old or new railway ties, telephone poles or wharves that were built of creosote treated wood.

The completed bridge should safely accommodate reasonably predictable levels of water flow.

##### **a. Bridge Location**

The alignment of a bridge relative to a waterway should be at right angles. This will reduce the length of bridge required to cross.

Bridges should not be located near abrupt bends in the channel.

Bridges should be located at a narrow section of the watercourse but where stream banks are stable and are not likely to erode under the bridge supports.

##### **b. Bridge Capacity**

The bridge must provide adequate capacity to safely discharge flood flows without causing backwater effects upstream or increased flow velocity downstream. Also bridges that are too small for the amount of water flow anticipated will likely be washed away.

Where insufficient information is available to estimate the maximum discharge at the site over a design period of reasonable length, the physical characteristics of the site may be utilized to determine the peak flow. The maximum historical water level as observed or recorded at the site may be used and a bridge should be built higher than this level. For minor bridges, such as those for ATVs, if the bottom of the bridge span is at the elevation of the top of the stream embankment it may be inferred that the bridge has the same capacity as the existing channel.

Bridge abutments must be set back at least 0.5 metres from the normal edge of the watercourse to prevent constriction during high flow conditions.

c. **Bridge Type**

Once a suitable site for the bridge is selected and having established the height and width requirements, one must then choose a type of bridge. Bridges for all terrain vehicles will typically be of timber construction with width adequate for one ATV. An example of acceptable bridge design is shown in the figure on the next page.

The basic design uses two or more sufficiently heavy logs laid on a flat rock or a log sill. Boards are nailed across the logs. A curb or toe-board should be provided to help guide the wheels and keep the ATV from running off the open edges. A solidly fastened handrail should also be added if the bridge is more than 1.12 metres (4 feet) high above the channel. If necessary, approach ramps can be made out of a few short boards or the gap can be filled with rocks. Pointed stakes should be driven into the ground to nail the bridge to in order to prevent the bridge from sliding off the sills and to prevent the bridge from washing away in the event of a flood.

### 3A ATV STREAM CROSSINGS

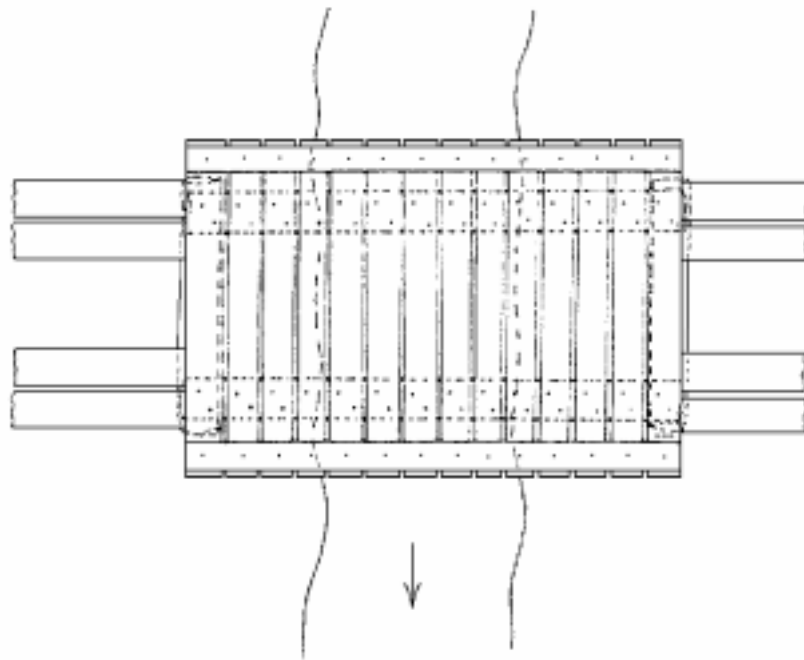
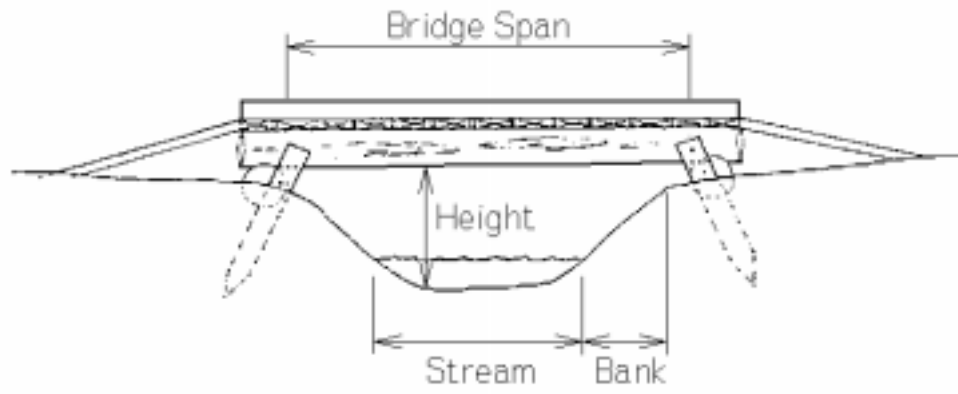

Profile and Plan of a Simple ATV Bridge

**5. Construction Practices**

At all times, every necessary precaution should be taken to prevent the disturbance of channel banks, bank vegetation, and land within the high water zone of the stream.

Any work that must be performed below the high water mark must be carried out during a period of low flow. It is not a good idea to do any work around a stream when the stream is in flood.

Winter is a good time for construction or at least for bringing materials to the site and for doing site preparation because one can work from an ice surface. No separate permits are required to cross ice covered bodies of water using an ATV or snowmobile.

All construction operations must be carried out in a manner that prevents damage to land, vegetation, and watercourses, and which prevents pollution of bodies of water.

The use of heavy equipment in streams or bodies of water is not permitted. The operation of heavy equipment must be confined to dry stable areas.

Wood preservatives such as penta, CCA or other such chemicals must not be applied to timber near a body of water. All treated wood or timber must be thoroughly dry before being brought to the site and installed. No treated wood shall be used on any portion of a trail that passes through a Protected Water Supply Area.

If the bridge is constructed using natural logs, then the bark should be removed from the logs. Peeled logs are better at resisting rot.

Abutments and piers must be constructed in the dry and during times of low flow.

The channel, including any land up to the high water mark, must be kept free of all excavated or unused construction materials at all times.

Where silted or muddied water has been generated, settling ponds, filtration or other suitable treatment must be provided to remove silt and turbidity before discharging into a body of water. It is best however to make sure that the work is performed without disturbing vegetative ground cover and thereby avoid causing any silting to occur in the first place.

### **3A ATV STREAM CROSSINGS**

#### **6. Inspection, Maintenance, and Other Concerns**

Bridges require frequent inspection to determine if they are performing satisfactorily without causing any environmental disruption, and to identify any problems which may threaten the structural integrity of the bridge.

General maintenance work should be carried out as required from time to time.

Periodic maintenance such as painting, resurfacing, clearing of debris, or minor repairs, must be carried out without causing any physical disruption of the watercourse. Care must be taken to prevent spillage of pollutants into the water.

#### **7. Site Restoration**

All areas affected by a project must be restored to a state that resembles local natural conditions. Further remedial measures to mitigate environmental impacts on water resources can and will be specified, if necessary in the opinion of this Department.

When the fording site or a bridge is no longer required, the owner must dismantle and remove all constructed works and restore the site to its original condition. All material placed in the stream must be completely removed from the channel.

#### **8. Applying for Environmental Approval for Stream Crossings**

All stream crossings must be approved in writing by the Minister before the crossing takes place or before beginning the construction of a bridge. Proponents should be aware that in addition to this requirement under Section 11 of the *Environment Act* other jurisdictions may require that the project be approved under their own legislation. A common example is the possible need to obtain a permit under *The Fisheries Act* if fish habitat is involved.

### **3A ATV STREAM CROSSINGS**

While these guidelines apply to any watercourse crossing no matter how small, written approval for each crossing need only be obtained for those stream crossings that appear on 1:50,000 scale topographic maps. An application form is attached in Appendix "A". One application must be completed for each type of stream crossing on each trail.

Applicants for licensed trails can apply for environmental approval for the necessary bridges either after the location of the trail is approved in principle by Crown Lands or at the same time. A recommendation that a trail will be eligible to be licensed must be made by Crown Lands before any certificate of approval is issued. Stream crossings on private land or any land that is not Crown Land must be approved under Section 11 but there is no need to have a licence for that trail. In such cases, proof of title or land ownership will be required before any written approval is issued.

In actually filling out the application form, it is important that the details be provided accurately and completely. Incomplete applications cannot be properly evaluated and they will be returned. Obviously, this will cause delays in getting approvals issued. Where dimensions are asked for, these dimensions must be obtained by taking actual measurements at the site of the proposed stream crossing. The bridge design should be customized for each site. In designing the bridge one should follow the important principles of these guidelines but actual details will be based on the actual site conditions, availability of materials to use for construction, ability and skill of the proponent and the constructability. Some people like to build elaborate structures, others prefer to keep things simple. Regardless of what these details actually are, they should be described fully in the application.

Each application will be evaluated to determine if the crossing is likely to avoid causing any impact on water resources. Applicants should be aware that structures are not evaluated for personal safety requirements or structural strength in terms of load carrying capacity. This is the owners sole responsibility. However, structures that appear likely to fail and can thereby cause obstruction of water flow or other environmental damage, can be refused environmental approval unless structural analysis is carried out.

The certificate of environmental approval will be subject to terms and conditions specifying such details as the location, size, materials, methods of construction, site preparation and restoration, and methods to control silt. These terms and conditions must be adhered to strictly. When the crossing is completed a completion report

### **3A ATV STREAM CROSSINGS**

which is a form attached to the certificate must be signed and returned promptly. A certificate of approval is generally valid for two years. This applies to the construction phase only. A bridge crossing can be used indefinitely as long as it is kept in good repair. A certificate of approval for fording will be valid only for the period specified in the certificate.

Applicants for approvals should note that it takes about 3 to 6 weeks to process an application for approval beginning from the time that it is received by the Water Resources Division. All applications are reviewed on a first come first serve basis. However, failure to provide complete information will result in delays since the proposal cannot be assessed properly and the approval may take considerably longer than 6 weeks.